

Deliveries to be only as per the approved sample. Any change in this document is the private property of the company. It must not be reproduced, disclosed to any tool (making, replacement) and material only with prior approval of the company. It must not be reproduced, disclosed to any third parties or used for manufacturing purposes without permission in writing from the company.

# BOBBIN DRAWING

FRONT VIEW

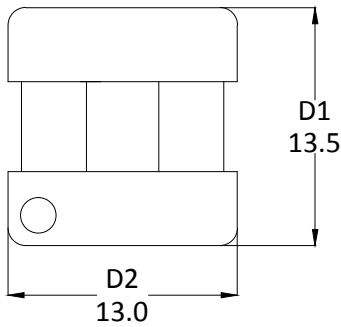

ELEVATION

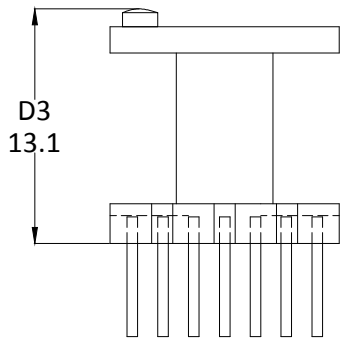

SIDE VIEW

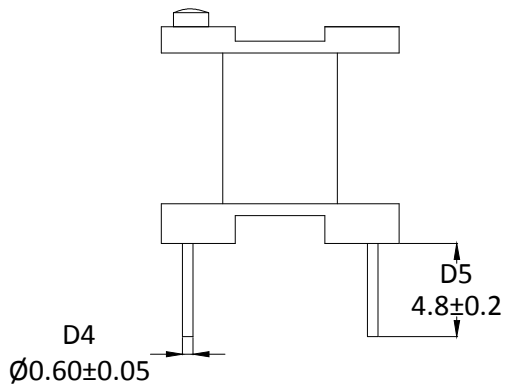

BOTTOM VIEW

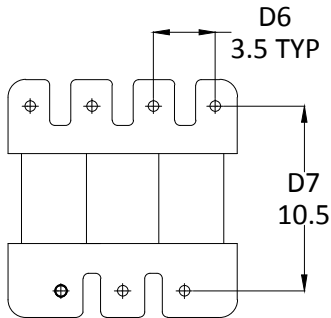

**Note:**

1. Pin pull out force : 10N Min.
2. Pin height can be changed as per customer request.

GENERAL TOLERANCE FOR UNSPECIFIED DIMENSION  
(DIN ISO 2768-1)

Tolerance class	LIMITS IN MM NOMINAL SIZE IN MM								RoHS COMPLIANT
	0.5 to 3	above 3 to 6	above 6 to 30	above 30 to 120	above 120 to 400	above 400 to 1000	above 1000 to 2000	above 2000 to 4000	
M (medium)	±0.1	±0.1	±0.2	±0.3	±0.5	±0.8	±1.2	±2	

MATERIAL: BOBBIN: PHENOLIC T375HF					PART DESC EI 16/4/5, (7 Pin) Bobbin				
					DWG NO SVM - BA179			SVM PART CODE BA179	
					REV 01		DATE 13.01.21		SHEET 1 of 1
CH LTR	ALT NO	SIGN	DATE	CHANGES				SCALE : NTS	
ALL DIMENSIONS ARE IN mm.								SIZE : A4	
 CHENNAI					DRAWN S.Sathish	REVIEWED BY QUALITY R.Yuvaraj	REVIEWED BY R&D B.M.Sundaram	APPROVED P.Dinesh	