

Deliveries to be only as per the approved sample. Any change in this document is the private property of the company. It must not be reproduced, disclosed to any tool (making, replacement) and material only with prior approval of the company. Any change in this document is the private property of the company. It must not be reproduced, disclosed to any tool (making, replacement) and material only with prior approval of the company.

BOBBIN DRAWING

FRONT VIEW

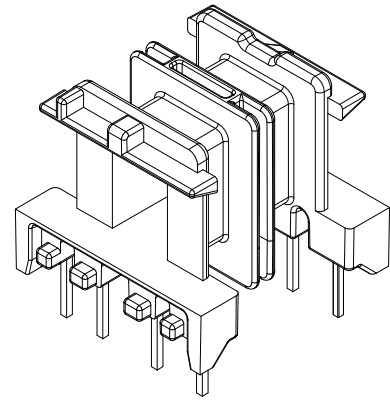
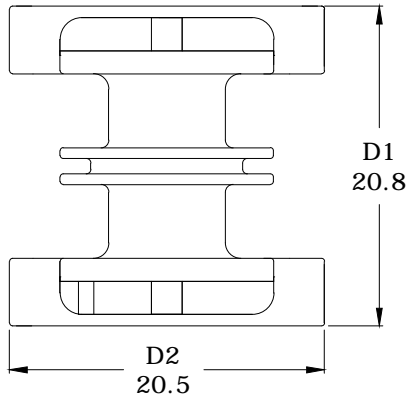

ELEVATION

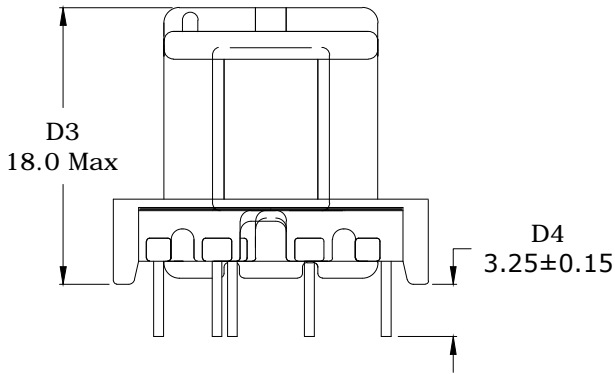

SIDE VIEW

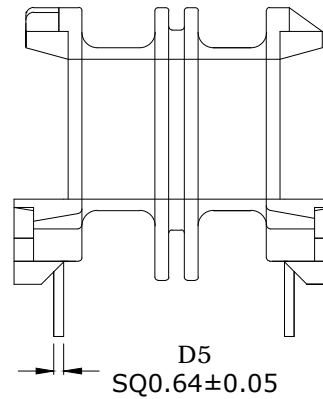

BOTTOM VIEW

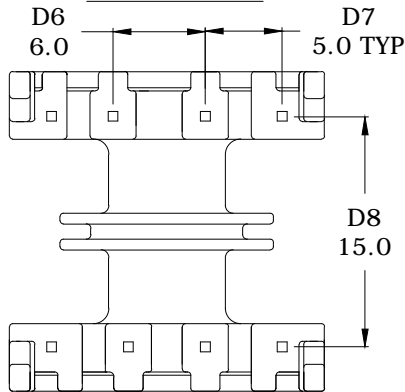

Note:

1. Pin pull out force : 10N Min.
2. Pin height can be changed as per customer request.

GENERAL TOLERANCE FOR UNSPECIFIED DIMENSION (DIN ISO 2768-1)

Tolerance -class	LIMITS IN MM NOMINAL SIZE IN MM								RoHS COMPLIANT
	0.5 to 3	above 3 to 6	above 6 to 30	above 30 to 120	above 120 to 400	above 400 to 1000	above 1000 to 2000	above 2000 to 4000	
M (medium)	±0.1	±0.1	±0.2	±0.3	±0.5	±0.8	±1.2	±2	

MATERIAL: PHENOLIC T375HF

PART DESC

EF- 20/10/9, 8PIN, 3Sec Horizontal Bobbin

DWG NO

SVM PART CODE

SVM - BA317

BA317

REV

DATE

SHEET

01

13.01.21

1 of 1

CH LTR

ALT NO

SIGN

DATE

CHANGES

ALL DIMENSIONS ARE IN mm.

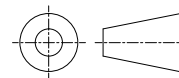

SCALE : NTS

SIZE : A4

svm
CHENNAI

DRAWN

REVIEWED BY
QUALITY

REVIEWED BY
R&D

APPROVED

S.Sathish

R.Yuvaraj

B.M.Sundaram

P.Dinesh