

BOBBIN DRAWING

TOP VIEW

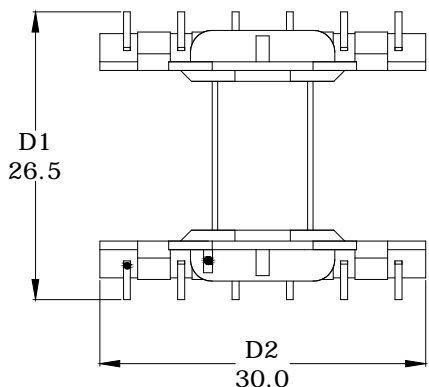

ELEVATION

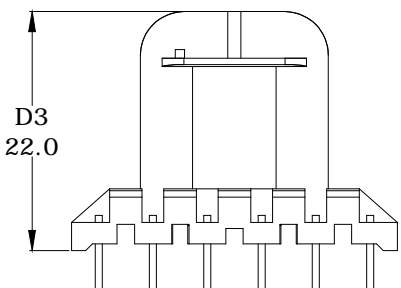

SIDE VIEW

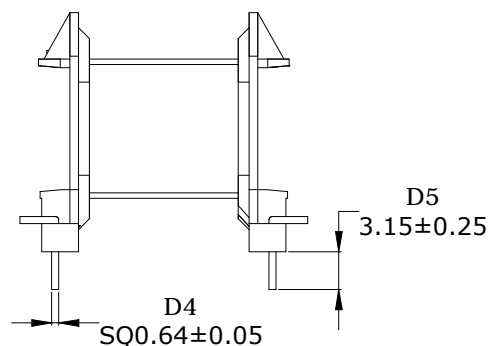

BOTTOM VIEW

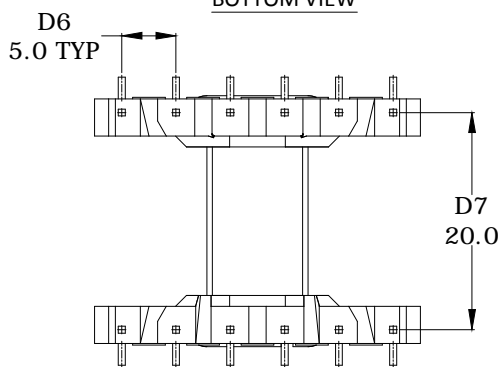

Note:

1. Pin pull out force : 10N Min.
2. Pin height can be changed as per customer request.

GENERAL TOLERANCE FOR UNSPECIFIED DIMENSION
(DIN ISO 2768-1)

Tolerance class	LIMITS IN MM NOMINAL SIZE IN MM							RoHS COMPLIANT		
	0.5 to 3	above 3 to 6	above 6 to 30	above 30 to 120	above 120 to 400	above 400 to 1000	above 1000 to 2000	above 2000 to 4000		
M (medium)	±0.1	±0.1	±0.2	±0.3	±0.5	±0.8	±1.2	±2		

MATERIAL: Bobbin: Ultramid A3x2g7 / Rynite FR530

PART DESC

EF 25/13/11-12 PIN(H) Bobbin

DWG NO

SVM- BA497

SVM PART CODE

BA497

REV

01

DATE

13.01.21

SHEET

1 of 1

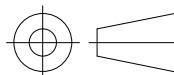

SCALE : NTS

SIZE : A4

CH LTR	ALT NO	SIGN	DATE	CHANGES

ALL DIMENSIONS ARE IN mm.

svm
CHENNAI

DRAWN

S.Sathish

REVIEWED BY
QUALITY

R. Yuvaraj

REVIEWED BY
R&D

B.M.Sundaram

APPROVED

P.Dinesh

This document is the private property of the company. It must not be reproduced, disclosed to any third parties or used for manufacturing purposes without permission in writing from the company.

Deliveries to be only as per the approved sample. Any change in tool (making, replacement) and material only with prior approval.