

# BOBBIN DRAWING

TOP VIEW

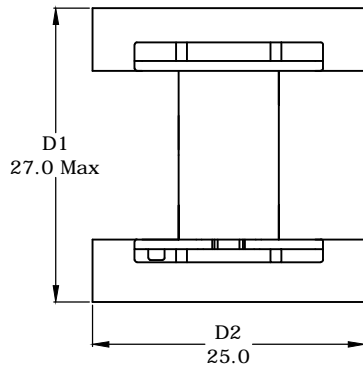

ELEVATION

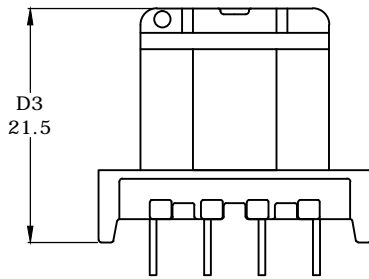

SIDE VIEW

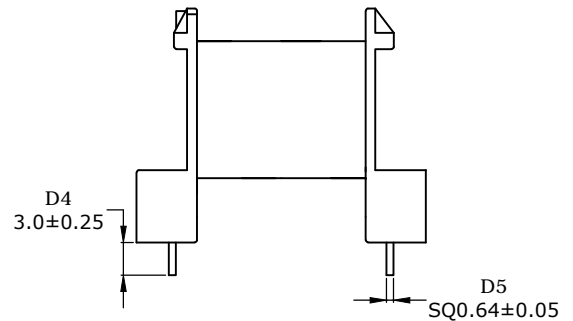

BOTTOM VIEW

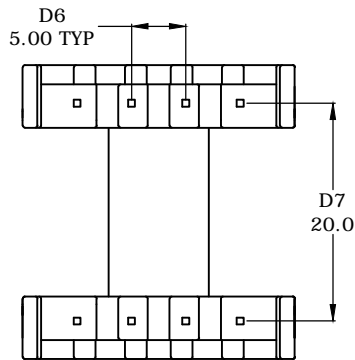

- Note:**
1. Pin pull out force : 10N Min.
  2. Pin height can be changed as per customer request.

GENERAL TOLERANCE FOR UNSPECIFIED DIMENSION  
(DIN ISO 2768-1)

Tolerance class	LIMITS IN MM NOMINAL SIZE IN MM							RoHS COMPLIANT	
	0.5 to 3	above 3 to 6	above 6 to 30	above 30 to 120	above 120 to 400	above 400 to 1000	above 1000 to 2000	above 2000 to 4000	
M (medium)	±0.1	±0.1	±0.2	±0.3	±0.5	±0.8	±1.2	±2	

MATERIAL: Bobbin: PHENOLIC T375HF

PART DESC

EF - 25/13/11, 8 PIN (H), Horizontal BOBBIN

DWG NO

SVM PART CODE

SVM - BA 645

BA 645

REV

DATE

SHEET

01

09.01.21

1 of 1

CH LTR	ALT NO	SIGN	DATE	CHANGES

ALL DIMENSIONS ARE IN mm.

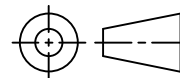

SCALE : NTS

SIZE : A4

**svm**  
CHENNAI

DRAWN

REVIEWED BY  
QUALITY

REVIEWED BY  
R&D

APPROVED

S.Sathish

R.Yuvaraj

B.M.Sundaram

P.Dinesh

This document is the private property of the company. It must not be reproduced, disclosed to any third parties or used for manufacturing purposes without permission in writing from the company.

Deliveries to be only as per the approved sample. Any change in tool (making, replacement) and material only with prior approval.