

BOBBIN DRAWING

TOP VIEW

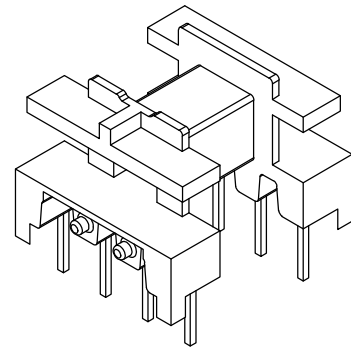

ELEVATION

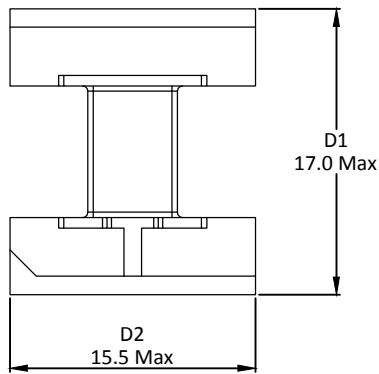
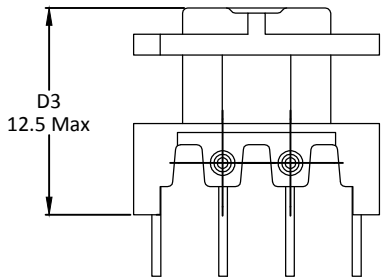

SIDE VIEW

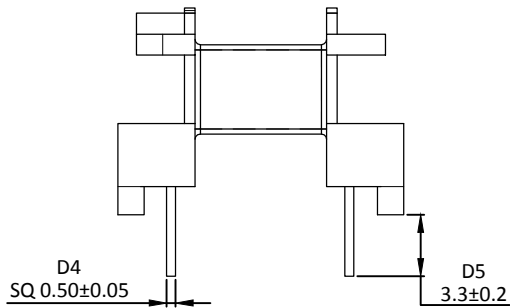

BOTTOM VIEW

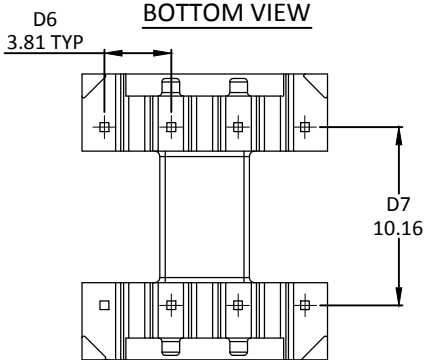

Note:

1. Pin pull out force : 10N Min.
2. Pin height can be changed as per customer request.

GENERAL TOLERANCE FOR UNSPECIFIED DIMENSION
(DIN ISO 2768-1)

Tolerance -class	LIMITS IN MM NOMINAL SIZE IN MM								RoHS COMPLIANT	
	0.5 to 3	above 3 to 6	above 6 to 30	above 30 to 120	above 120 to 400	above 400 to 1000	above 1000 to 2000	above 2000 to 4000		
M (medium)	±0.1	±0.1	±0.2	±0.3	±0.5	±0.8	±1.2	±2		

MATERIAL: PHENOLIC T375 HF

PART DESC

E13x7x4, 8Pin (H) bobbin

DWG NO

SVM - BA713

SVM PART CODE

BA713

REV

01

DATE

08.01.21

SHEET

1 of 1

CH LTR

ALT NO

SIGN

DATE

CHANGES

ALL DIMENSIONS ARE IN mm.

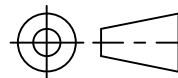

SCALE : NTS

SIZE : A4

svm
CHENNAI

DRAWN

S.Sathish

REVIEWED BY
QUALITY

R.Yuvaraj

REVIEWED BY
R&D

S.Venkat

APPROVED

P.Dinesh

Deliveries to be only as per the approved sample. Any change in tool (making, replacement) and material only with prior approval.