

This document is the private property of the company. It must not be reproduced, disclosed to any third parties or used for manufacturing purposes without permission in writing from the company.

Deliveries to be only as per the approved sample. Any change in tool (making, replacement) and material only with prior approval.

## BOBBIN DRAWING

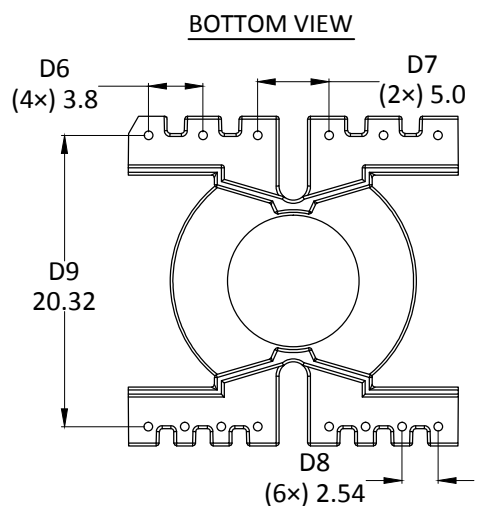
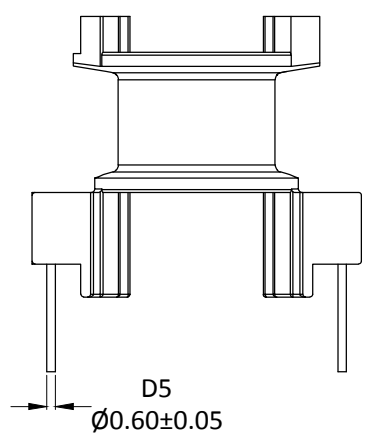
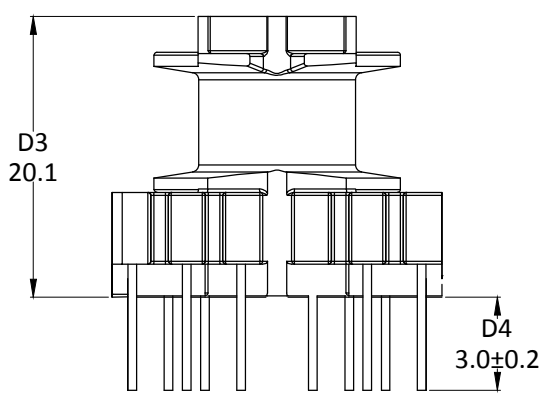
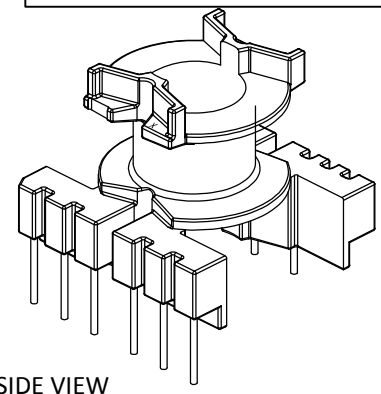
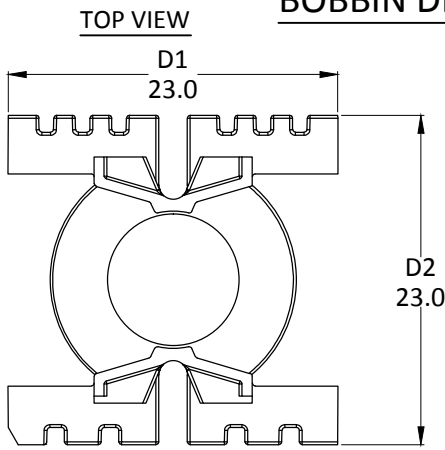

- Note:**
1. Pin pull out force : 10N Min.
  2. Pin height can be changed as per customer request.

GENERAL TOLERANCE FOR UNSPECIFIED DIMENSION (DIN ISO 2768-1)

Tolerance class	LIMITS IN MM NOMINAL SIZE IN MM								RoHS COMPLIANT
	0.5 to 3	above 3 to 6	above 6 to 30	above 30 to 120	above 120 to 400	above 400 to 1000	above 1000 to 2000	above 2000 to 4000	
M (medium)	±0.1	±0.1	±0.2	±0.3	±0.5	±0.8	±1.2	±2	

MATERIAL : Bobbin : Phenolic T375HF					PART DESC					
					PQ 20X16, 14PIN, (V) bobbin					
					DWG NO			SVM PART CODE		
					SVM - BA720			BA720		
					REV		DATE		SHEET	
					01		30.12.20		1 of 1	
CH LTR	ALT NO	SIGN	DATE	CHANGES						
ALL DIMENSIONS ARE IN mm.										
<b>svm</b> CHENNAI							SCALE : NTS			SIZE : A4
DRAWN		REVIEWED BY QUALITY		REVIEWED BY R&D		APPROVED				
S.Sathish		R.Yuvaraj		B.M.Sundaram		P.Dinesh				