

This document is the private property of the company. It must not be reproduced, disclosed to any third parties or used for manufacturing purposes without permission in writing from the company.

Deliveries to be only as per the approved sample. Any change in tool (making, replacement) and material only with prior approval.

BOBBIN DRAWING

TOP VIEW

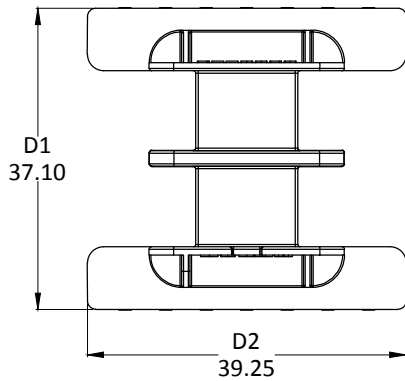

ELEVATION

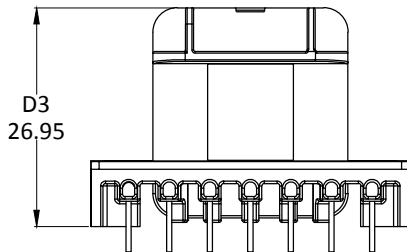

BOTTOM VIEW

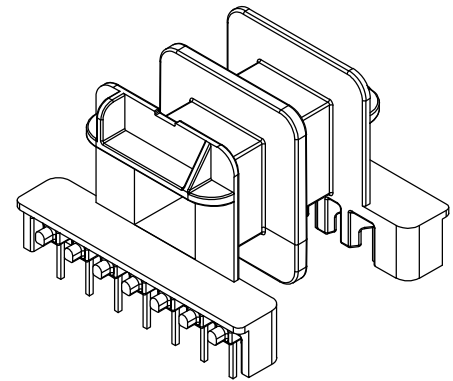
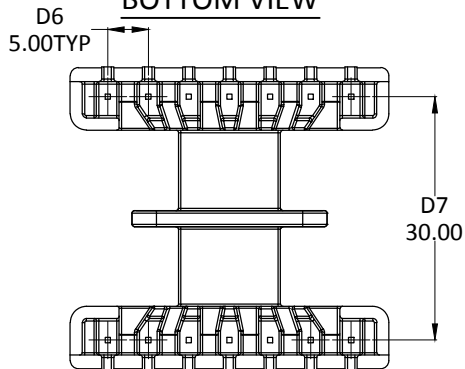

SIDE VIEW

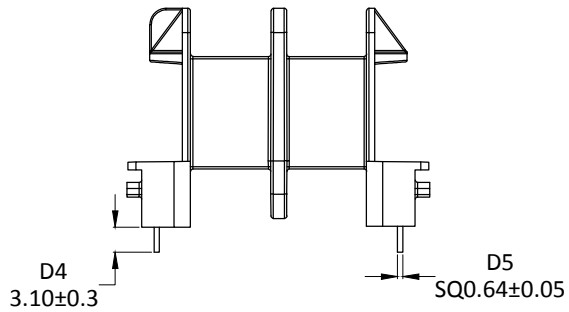

- Note:**
1. Pin pull out force : 10N Min.
 2. Pin height can be changed as per customer request.

GENERAL TOLERANCE FOR UNSPECIFIED DIMENSION
(DIN ISO 2768-1)

Tolerance class	LIMITS IN MM NOMINAL SIZE IN MM							RoHS COMPLIANT		
	0.5 to 3	above 3 to 6	above 6 to 30	above 30 to 120	above 120 to 400	above 400 to 1000	above 1000 to 2000	above 2000 to 4000		
M (medium)	±0.1	±0.1	±0.2	±0.3	±0.5	±0.8	±1.2	±2		

MATERIAL : Bobbin : RYNITE FR530				
CH LTR	ALT NO	SIGN	DATE	CHANGES
ALL DIMENSIONS ARE IN mm.				

PART DESC			
E36/18/11, 2SEC, 14PIN HORIZONTAL BOBBIN			
DWG NO		SVM PART CODE	
SVM -BA743		BA743	
REV	DATE	SHEET	
A	30.12.20	1 of 1	
		SCALE : NTS	
		SIZE : A4	
DRAWN	REVIEWED BY QUALITY	REVIEWED BY R&D	APPROVED
S.Sathish	R.Yuvaraj	B.M.Sundaram	P.Dinesh

svm
CHENNAI